

REGIONAL MONITORING OF TROPOSPHERIC NO₂ AND CO USING REMOTE SENSING FROM HIGH ALTITUDE PLATFORMS - PRELIMINARY CONCEPTS

M. De Maziere^{a,*}, M Van Roozendael^a, A. Merlaud^a

^a Belgian Institute for Space Aeronomy (BIRA-IASB), 3, avenue Circulaire, 1180 Brussels, Belgium - (martine.demaziere, michelv, alexism)@aeronomie.be

KEY WORDS: Atmosphere, Tropospheric Pollution Monitoring, Carbon Monoxide, Nitrogen Dioxide, Remote Sensing, UV and IR spectroscopy, High Altitude Long Endurance Unmanned Aerial Vehicle (HALE-UAV)

ABSTRACT:

The study of human emissions in the atmosphere and their influence on air quality and climate change is a major scientific issue in today's atmospheric research. Unmanned Aerial Vehicles (UAV) can be used as new platforms for remote sensing of chemicals in the atmosphere, to provide complementary information to the existing measurements. Compared to satellite observations, the spatial and temporal resolutions can be improved, and contrary to ground-based measurements, a regional coverage can be assured. A special focus can be put on areas in the neighbourhood of emission sources. These benefits would be useful to constrain efficiently existing models of atmospheric chemistry and transport and hence improve the so-called chemical weather predictions. This paper describes the initiation of a study concerning the development of a measurement system to be installed on a UAV, designed for the observation of two major tropospheric pollutants, namely carbon monoxide (CO) and nitrogen dioxide (NO₂).

1. INTRODUCTION

It is well established nowadays that there exists a significant human impact on our environment. Particularly, anthropogenic gas emissions in the troposphere above industrial areas modify the properties of the atmosphere with worrying long-term consequences, e.g., on public health, that are difficult to predict. Therefore it is an important scientific challenge to characterize the amount and effect of those emissions on air quality and climate change, and to provide support to the relevant environmental policies. Research focuses on the development of appropriate chemistry-transport models, as well as on the improvement of observation methods. Direct samplings, also called in-situ measurements, are achieved by ground networks such as GAW (Global Atmosphere Watch, http://www.wmo.ch/web/arep/gaw/gaw_home.html), and from balloons or aircrafts (e.g., MOZAIC, Measurement of Ozone water vapour, carbon monoxide and nitrogen oxides by Airbus In-service airCraft, <http://mozaic.aero.obs-mip.fr/>). The techniques are well calibrated and enable the study of variations and trends at local points but mostly on the ground, near the tropopause and around airports in the troposphere. Remote sensing methods, based on UV, visible and IR spectroscopy, are also used and enable to estimate the abundance of chemical species integrated along an effective line of sight (column). Advanced inversion techniques provide some vertically resolved information about the distribution of the target species in the atmosphere (Rodgers, 2000). Measurements are done from the ground (e.g., NDACC, <http://www.ndacc.org>), from balloons and from satellites. Among the latter, actual ones that include observations of nitrogen dioxide (NO₂) and/or carbon monoxide (CO) and that we are involved with, are GOME (Global Ozone Monitoring Experiment, <http://earth.esa.int/ers/gome/>), SCIAMACHY (SCanning Imaging Absorption spectroMeter for Atmospheric CHartographY, <http://earth.esa.int/object/index.cfm?fobjectid=1671>, OMI

(Ozone Monitoring Instrument, <http://aura.gsfc.nasa.gov/instruments/omi/>), and IASI (Infrared Atmospheric Sounding Interferometer, http://www.eumetsat.int/Home/Main/What_We_Do/Satellites/EUMETSAT_Polar_System/Space_Segment/SP_1139327368243?l=en). The achieved vertical resolution in the troposphere is however limited for these types of measurements. Ground-based sensors are mainly placed far away from local sources whereas satellite-embedded instruments, if providing global coverage, present a low spatial (of order 15x15 km²) and temporal (some days) resolution. This is illustrated in Table 1 for the nadir observation of NO₂ by the previously cited satellite instruments GOME, SCIAMACHY and OMI.

Instrument	Launch	Resolution		
		Vertical	Horizontal	Time
GOME	1995	Troposphere column	320x40 km ²	3 days at equator
SCIAMACHY	2002	Troposphere column	60x30 km ²	6 days at equator
OMI	2004	Troposphere column	13x24 km ²	1 day

Table1. Resolution achieved for the measurement of NO₂ from the satellite instruments GOME, SCIAMACHY and OMI.

Remote sensing from an Unmanned Aerial Vehicle (UAV) could fill these gaps in the measurements and provide accurate enough data to constrain the existing models. The exploitation of UAV for applications in atmospheric research has already been demonstrated, for example for the monitoring of clouds

* Corresponding author

and aerosol (<http://www.er.doe.gov/ober/CCRD/uav.html>), as well as for in situ measurements of atmospheric trace gases (Fahey et al., 2006). Investigations are thus carried out now at BIRA-IASB regarding the design of a payload for remote sensing of key species in atmospheric pollution, namely carbon monoxide (CO) and nitrogen dioxide (NO₂), to be put onboard a UAV. The objectives are to provide observations on a regional scale, possibly above areas with high emissions, with a higher spatial and temporal resolution than can be achieved from today's satellite experiments.

The following sections discuss the rationale for the choice of the target species (Section 2), the platform characteristics (Section 3), the initial phase of the study of the sensor design (Section 4) and finally (Section 5), the inversion techniques available at BIRA-IASB for data processing.

2. TARGET SPECIES

European legislation (1999/30/EC, 2000/69/EC, 2002/3/EC) requires the monitoring of major pollutants including O₃, NO₂, SO₂, CO, and small particles, in particular PM10 (particles with a diameter less than 10 μm). The focus of our study concerns (a) payload(s) for the observation of tropospheric CO and NO₂, two species whose anthropogenic emissions exceed natural ones (Mouvier, 1998).

2.1 Carbon Monoxide

This gas affects the oxidizing capacity of the troposphere and the concentration of greenhouses gases such as methane and ozone, and thus plays a major role in climate change and air quality.

The main sources of CO are fossil fuel combustion, biomass burning and oxidation of methane and other hydrocarbons. Its relatively long lifetime (1 to 3 months) in the atmosphere makes it a good tracer of pollution. If satellite and ground-based measurements are extensively done, the World Meteorological Organisation/Global Atmosphere Watch (WMO/GAW) recommends the development of small airborne platforms to improve the profile information as well as the time and space resolution of the measurements, especially in regions with high emissions (Klausen, J., 2006).

Remote sensing of CO is achieved in the thermal infrared (TIR) using its 1-0 absorption band at 4.6 μm. The overtone 2-0 band, in the Short-Wave infrared (SWIR) at 2.3 μm is also used. Figure 1 shows both CO absorption bands.

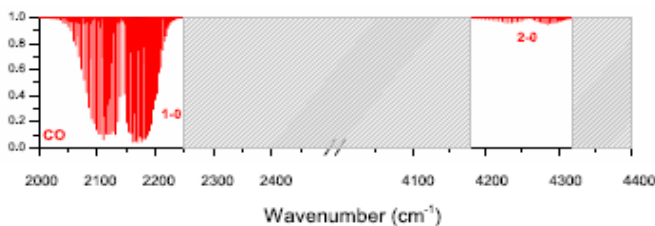

Figure 1. CO 1-0 and 2-0 absorption bands in the TIR (2000-2250 cm⁻¹) and the SWIR (41805-4320 cm⁻¹) regions, in transmittance units. (from Coheur et al., 2005)

Complementary information can be obtained from the two regions, with 4.6 μm measurements providing data weighted to the upper troposphere and observations at 2.3 μm being dominated by sunlight reflected on the ground and hence providing the CO column down to the surface. Simultaneous measurements in the two bands enable thus to estimate the

tropospheric and boundary layer abundances of CO. Figure 2 illustrates these different sensitivities via the averaging kernel functions, which are defined as being the derivative of the retrieved vertical distribution of CO at a certain altitude to the real distribution. The example case shown corresponds to a nadir observation from geostationary satellite. One clearly sees that the thermal infrared (left plot) has poor sensitivity at ground level; the highest sensitivity is obtained between 3 and 7 km altitude. The SWIR channel (middle plot) is most sensitive to surface and boundary layer CO. The combined use of both channels (right plot in Figure 2) enables sensitive sounding of the CO concentrations from the surface to the free troposphere.

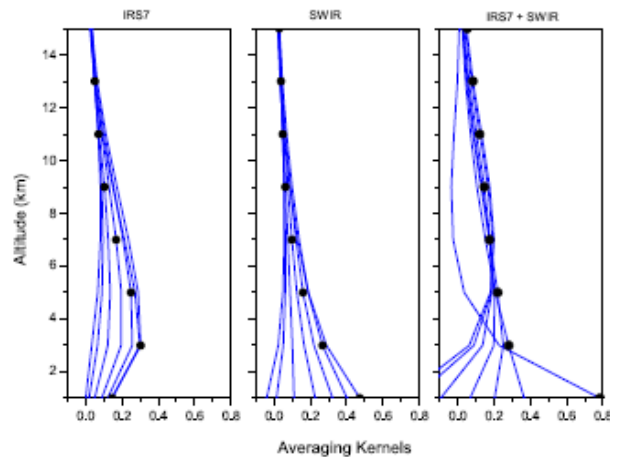

Figure 2. Averaging kernels for CO from the TIR (left plot) and SWIR (middle plot) bands alone and in synergy (right plot). The spectral resolution and instrumental noise are 0.625 cm⁻¹ and 5 10⁻⁹ W/(cm² sr cm⁻¹) in TIR and 0.4 cm⁻¹ and 500 signal-to-noise ratio in the SWIR, respectively. Each curve represents the averaging kernel at the altitude indicated by the black bullet. (from Coheur et al., 2005)

2.2 Nitrogen dioxide

Tropospheric NO₂ is produced mainly in biomass burning, fuel combustion, and electrical installations. Naturally, it is also emitted by soils and produced by lightning. It is involved in ozone production in the presence of hydrocarbons, and leads also to particles and acid rain formation. Its lifetime is short (order of magnitude of one day). Therefore, tropospheric NO₂ is mainly localised close to its sources.

Tropospheric NO₂ has been measured from ground observatories (Petritoli et al., 2004) and from satellites (e.g. Richter et al., 2005; van der A et al., 2006), but one needs more frequent observations, especially over source regions, on the small to regional scales.

Optical remote sensing measurements of NO₂ use the spectral properties of the scattered light in the UV-visible range around 440 nm. The most commonly used method to determine the abundance of NO₂ from the spectra is the so-called Differential Optical Absorption Spectroscopy (DOAS) method (Platt, 1994): the analysis of the high-frequency structures of the NO₂ absorption bands in the scattered light signal enables the determination of the atmospheric NO₂ column abundances.

3. CHARACTERISTICS OF THE PLATFORM AND PAYLOAD REQUIREMENTS

The targeted platform type is a High Altitude Long Endurance Unmanned Aerial Vehicle (HALE-UAV). These aircrafts are powered by solar panels and are designed to fly during several months at a stable altitude above controlled air traffic (~14 km). It offers the possibility to cover regions of the order of 150 000 km² but it can also hover over small areas, thus providing a continuous survey. We have a special interest in the platform that will be used by the Vlaamse Instelling voor Technologisch Onderzoek (VITO) for the PEGASUS project, called Mercator 1 and built by Verhaert Space. The aircraft, with an 18 m wingspan, will be able to carry a payload of about 2.5 kg, for operation during three months. Solar panels will deliver 50 W during daytime to be used for the instruments and data transmissions. The payload, installed in the front of the plane, must fit in a cylinder with a 10 cm diameter and 1 m long. This cylinder can theoretically rotate freely around the main axis of the aircraft, since it is not placed under the wings. Expected temperature at this altitude varies between -70 °C and +10 °C and hence the payload must be designed to support these large variations.

4. SENSOR DESIGN

Instrument configurations fitting the requirements are now investigated. Due to the weight and size limitations described above, the plan is to have two payloads for the two species needing different spectroscopic systems.

4.1 UV-visible spectrometer for NO₂ and possibly additional species

In the UV-Visible range, the required resolution is around 1 nm to adequately sample the cross-section structures of NO₂. Ocean Optics USB4000 (<http://www.oceanoptics.com/Products/usb4000.asp>) and similar spectrometers have been widely used in the DOAS community. Those devices include a grating, a linear array CCD detector and optics mounted in a compact way. They are small (89.1 mm x 63.3 mm x 34.4 mm) and light (190 g), and could thus be adapted relatively easily to fit in the payload. The standard set-up to produce spatial information with such a one-dimensional detector is the so-called whisk-broom sensor, or cross-track scanner, where scanning optics is needed to sweep the targeted object. Imaging spectrometers such as the Micro-Hyperspec from Headwall (http://www.headwallphotonics.com/downloads/Micro_Hyperspec_DS_Headwall.pdf, 110 mm * 93 mm * 50 mm) are also considered, since new developments and miniaturisation in the technology make this kind of spectrometers attractive for our application. In this case, a two-dimensional detector is used in push-broom, or along-track scanning mode, and no movement of the objective is required. Figure 3 illustrates both scanning modes.

The cylindrical shape and the position of the payload described in the previous part is especially interesting since it enables multiple viewings (nadir, zenith and slant path) and could thus be used in our application.

The possibility to simultaneously detect other species in the UV-Visible region like SO₂ is also considered in the search for an adequate solution, especially since a custom grating will probably have to be manufactured anyway.

4.2 IR sensor

For the 2.3 and 4.6 μm CO bands, we estimate an appropriate spectral resolution to be around 0.05 cm⁻¹ (width of the CO lines at 14 km). Commercial spectrometers exist for the SWIR band, such as the Ocean Optics NIR 256 (<http://www.oceanoptics.com/Products/nir256.asp>, 153.4 mm x 105.2 mm x 76.2 mm, 980 g), however their spectral resolutions are limited. Detectors working in the infrared region must be cooled in order to reduce the thermal noise, especially toward longer wavelengths. Compact thermoelectrically cooled detectors systems are thus investigated such as the ones provided by Hamamatsu and Judson Technologies. At present, we have not yet concluded which type of spectrometer we will use and several options are still under consideration. BIRA-IASB has acquired experience with compact Acousto-Optic Tunable Filter (AOTF) spectrometer systems (Nevejans et al., 2006) and this option is still being investigated. Fabry-Perot spectrometers are also interesting due to their relatively small size and high spectral resolution. Other options such as the technique of Gas Filter Correlation Radiometry used in the space experiments MAPS (Measurement of Air Pollution from Satellites) (Reichle et al., 1994) and MOPITT (Measurements Of Pollution In The Troposphere) (Drummond, 1989 and Drummond et al., 1996) must also be looked at (Sachse et al., 2005).

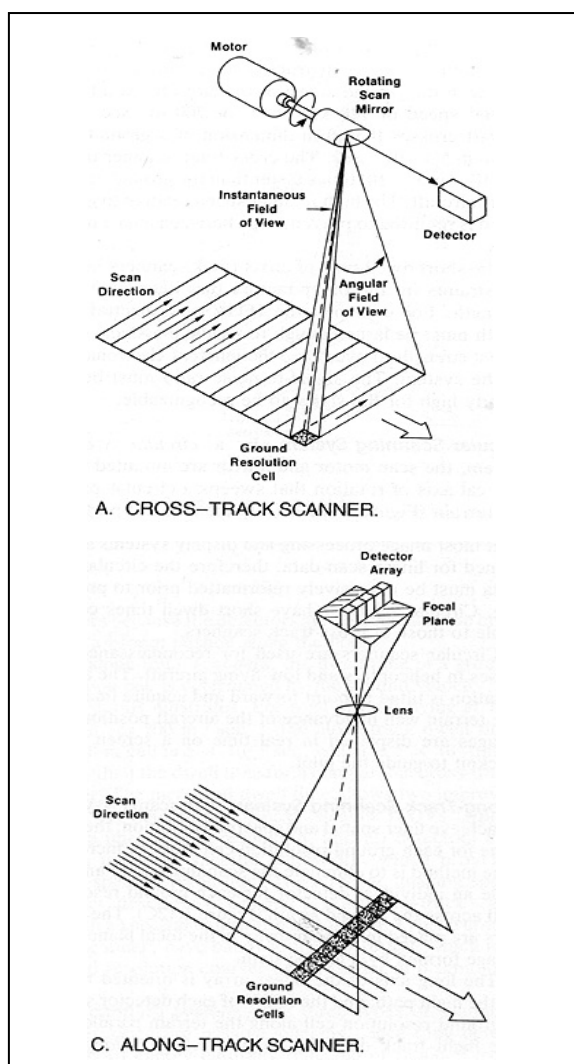

Figure 3. Different scanning modes used with linear (A) and 2-dimensional (C) detectors
(from http://rst.gsfc.nasa.gov/Intro/Part2_5a.html)

5. DATA RETRIEVALS

BIRA-IASB has a long-lasting experience in the operation of spectroscopic instruments for remote sensing of the atmospheric composition, both in the UV-visible and infrared domains. It has also developed and implemented several codes for the retrieval of atmospheric compounds from such spectral measurements, made from ground or from space, in both spectral ranges. In the UV-visible range, WinDOAS (www.oma.be/BIRA-IASB/Molecules/BrO/WinDOAS-SUM-210b.pdf) has been used and widely distributed for many years. More recently the GODFIT/GOPAS code based on the LIDORT radiative transfer code has been developed for both space nadir and ground-based atmospheric column retrievals (Van Roozendaal et al., 2006). At the institute, we also developed software for the inversion of atmospheric remote sensing data in the infrared from space-borne nadir and limb and ground-based sensors. The most recent implementation is called ASIMUT (Vandaele et al., 2006): this tool is suitable for the inversion of the data that will be measured by the IR sensors onboard the UAV.

6. CONCLUSION

A new tool for atmospheric remote sensing, based on spectroscopic instrumentation in the UV-visible and infrared spectral ranges onboard a HALE-UAV, is being investigated at BIRA-IASB. The objectives are to improve the regional monitoring of carbon monoxide and nitrogen dioxide, while filling some gaps regarding the spatial and temporal resolution in the actually available data sets from airborne, and space- and ground-based sensors. A long-term goal is to provide data that can enhance the accuracy of regional chemistry-transport models. The main challenge now is the design of a compact instrument fitting simultaneously the requirements of the platform and the scientific objectives. First results are expected on a middle-term time scale of 3-4 years.

REFERENCES

- Coheur, P.F., B. Barret, C. Clerbaux, J. Hadji-Lazaro, M. Kruglanski, A.C. Vandaele, and D. O'Brien, 2005. CO measurements from MTG IRS and UVS missions, EUM/CO/04/1296/SAT, Final Report.
- Drummond, J., 1989. Novel correlation radiometer: the length-modulated radiometer, *Appl. Opt.*, 28, 2451.
- Drummond, J. and G. Mand, 1996. The Measurements of Pollution in the Troposphere (MOPITT) Instrument: Overall Performance and Calibration Requirements, *Journal of Atmospheric and Oceanic Technology*, 13, 314.
- Fahey, D. W., J.H. Churnside, J.W. Elkins, A.J. Gasiewski, K.H. Rosenlof, S. Summers, M. Aslaksen, T.A. Jacobs, J.D. Sellars, C.D. Jennison, L.C. Freudinger, and M. Cooper, 2006. Altair unmanned aircraft system achieves demonstration goals, *EOS*, 87 (20), 197.
- Klausen, J., 2006. Joint WMO-GAW/ACCENT Workshop on The Global Tropospheric Carbon Monoxide Observations System, Quality Assurance and Applications (EMPA, Dübendorf, Switzerland, 24 – 26 October 2005), World Meteorological Organization / Global Atmosphere Watch, Report n° 166. <http://www.wmo.int/web/arep/gaw/gawreports.htm>.
- Mouvier G., 1998, *La Pollution Atmospherique*, Flammarion, France pp. 11-14
- Nevejans, Dennis, Eddy Neefs, Emiel Van Ransbeeck, Sophie Berkenbosch, Roland Clairquin Lieve De Vos, Wouter Moelans, Stijn Glorieux, Ann Baeke, Oleg Korablev, Imant Vinogradov, Yuri Kalinnikov, Benny Bach, Jean-Pierre Dubois, Eric Villard, 2006. Compact high-resolution space-borne echelle grating spectrometer with AOTF based order sorting for the infrared domain from 2.2 to 4.3 micrometer, *Appl. Optics*, 45, 5191-5206.
- Petriloti, A., P. Bonasoni, G. Giovanelli, F. Ravegnani, I. Kostadinov, D. Bortoli, A. Weiss, D. Schaub, A. Richter, and F. Fortezza, 2004. First Comparison Between ground-based and Sattelite-borne Measurements of Tropospheric Nitrogen Dioxide in the Po Basin, *J. Geophys. Res.*, 109, D15307, doi:10.1029/2004JD004547.
- Platt, U., 1994. Differential optical absorption spectroscopy (DOAS), *Air Monitoring By Spectrometric Techniques*, edited by M. W. Sigrist, Chemical Analysis Series, 127, 27-84, John Wiley & Sons, Inc.
- Reichle, H., Jr., V. Connors, J. Holland, W. Hypes, H. Wallio, J. Casas, B. Gormsen, M. Saylor, and W. Hesketh, 1986. Middle and upper tropospheric carbon monoxide mixing ratios measured by a satellite-borne remote sensor during November 1981, *J. Geophys. Res.*, 91, 10865-10887.
- Richter, A., J. P. Burrows, H. Nüß, C. Granier, U. Niemeier, 2005. Increase in tropospheric nitrogen dioxide over China observed from space, *Nature*, 437, 129-132, doi: 10.1038/nature04092.
- Rodgers, C. D., 2000. Inverse methods for atmospheric sounding. Theory and Practice. World Scientific. Series on Atmospheric, Oceanic and Planetary Physics – Vol. 2.
- Sachse, G., R. Bradley Pierce, James Crawford, and Vickie Connors, 2005. Decadal Survey Submission: Low-Earth-Orbit Global Mapping Of Boundary Layer Carbon Monoxide, private communication.
- Vandaele, A.C., M. Kruglanski, and M. De Mazière, 2006. Modeling and retrieval of atmospheric spectra using ASIMUT, Proceedings of the ESA Atmospheric Science Conference (May 8-12, 2006, Frascati, Italy).
- van der A R. J., D. H. M. U. Peters, H. Eskes, K. F. Boersma, M. Van Roozendaal, I. De Smedt, H. M. Kelder, 2006. Detection of the trend and seasonal variation in tropospheric NO₂ over China, *J. Geophys. Res.*, 111, D12317, doi:10.1029/2005JD006594.
- Van Roozendaal M., et al., 2006. Ten years of GOME/ERS-2 total ozone data — The new GOME data processor (GDP) version 4: 1. Algorithm description, *J. Geophys. Res.*, 111, D14311, doi:10.1029/2005JD006375.

ACKNOWLEDGEMENTS

We thank Prof. A. Cornet from the University of Louvain for useful discussions.